

Hydraulic Rail Profile Grinder 910215 Operating Manual



Hydraulic Rail Profile Grinder 910215 Record of Changes

Rev No.	Date	Description of Changes
Rev 1	4.2023	Initial release.
Rev 1.1	10.2023	Update Technical Support & Service information

Table of Contents

Section 1: Overview and Safety	5
Hydraulic Rail Profile Grinder Overview	5
Environmental Protection	5
Safety Information	6
Safety Terms	6
Machine Use and Safety Precautions	6
Section 2: Specifications and Installation	8
Specifications	8
Hydraulic fluid	8
Hydraulic System Specification	8
Components	9
Installation	10
Hose Requirements	10
Hose Types	11
Hydraulic Hose Recommendation	12
Hydraulic Fluid Recommendation	12
Tool Connecting Procedures	13
Disconnecting Hoses	13
Section 3: Tool Operation	14
Personal Protective Equipment	14
Grindstone Installation	14
Grinder Functional Test	16
Stone Height Adjustment	17
Operation	17
Frame Rotation	18
Positioning on the Rail	18
Section 4: Maintenance	19
Troubleshooting	20
Maintenance Schedule	20
Troubleshooting	21
Section 5: Parts and Service Support	22
On-Off Rotary Valve Exploded View & Parts List	22
Motor Exploded View	24
Motor Exploded View Parts List	25

Handle Exploded View & Parts List	26
Frame Exploded View & Parts List	27
Profile Grinder Exploded View	28
Profile Grinder Exploded View Parts List.....	28
Section 6: Warranty Terms and Conditions	30

Section 1: Overview and Safety

Hydraulic Rail Profile Grinder Overview

Racine Railroad Products designs and manufactures equipment primarily for the repair and new construction of rail and railroad tie track maintenance.

The Hydraulic Rail Profile Grinder uses a high-efficiency, pressure loaded hydraulic motor that provides maximum power while reducing heat and minimizing energy waste.

The smooth-operating stone height adjustment is well within easy reach of the operator. Lifting handles are balanced for ease in transport. Stone access panel and shaft lock make for easy stone removal. The quick latch is easily adjustable for carriage positioning.

Use grinding discs with approximately 15.24 cm (6 inch) diameter and 7.62 cm thickness (3 inch). The grinding discs must be suited for use at 3,300 rpm.

Over speed valves protect the motor and stone from excess RPM. Spark guard offer optimum protection. Convenient handle with trigger guard automatically stops the tool operation when released.

Do not use this machine for other than its intended purpose.

Please read these instructions when using this tool, which can only be used for the specified purpose. This instruction manual should be kept throughout the life of the tool.

The operator of this tool should:

- Have access to this operation instruction.
- Read and understand this operation instruction.
- Read and understand this operation instruction.

Note: Information in this document is subject to change without notice.

Environmental Protection



Comply with relevant national waste disposal laws and regulations. Waste electronic devices cannot be treated as household waste.

Equipment, accessories, and packaging shall be recyclable.



Don't throw the discarded equipment in trash cans.

Safety Information

For safe installation and operation of this equipment, carefully read and understand the contents of this manual. Improper operation, handling, or maintenance can result in equipment damage and personal injury.

Only trained and authorized personnel should be allowed to operate this machine. In addition, all personnel at the worksite should be aware of the safety concerns and their individual responsibilities prior to working with this machine.

Please read and comply with all the safety precautions in this manual **before** operating this machine. Your safety is at risk.

Safety Terms

**DANGER**

DANGER indicates a hazardous operating procedure, practice, or condition. If the hazardous situation is not avoided death or serious injury will occur.

**WARNING**

WARNING indicates a hazardous operating procedure, practice, or condition. If the hazardous situation is not avoided death or serious injury could occur.

**CAUTION**

CAUTION indicates a potentially hazardous operating procedure, practice, or condition. If the hazardous situation is not moderate or minor injury could occur.

Machine Use and Safety Precautions

**WARNING**

Failure to follow safety precautions when operating this equipment can result in serious injury or death to the operator or other persons in the area.

Observe the following precautions whenever you are operating, working on or near this equipment.

Do not use this machine for other than its intended purpose.

Do not make any modifications without authorization or written approval from Racine Railroad Products. Replace all Racine Railroad Products and OEM parts with genuine Racine Railroad Products and OEM parts. Using non-OEM parts may compromise the safety of the machine.

Do not wear loose clothing, jewelry, radio belts, etc., when operating, working on or near this equipment. They can be caught in moving parts and may result in severe injury.

Always wear appropriate personal protective clothing when operating this equipment: e.g., orange safety vest, hard hat, safety glasses with side shields, hearing protection, steel-toed safety boots, leather gloves, dust respirator, etc.

Always lift heavy objects with the knees and legs, not the arms and back.

Always keep hands, arms, feet, head, clothing, etc., out of the operating area and away from all rotating or moving components when operating, working on or near this machine.

Always make sure that all guards, covers, belts, hoses, and operating components are in good working order and that all controls are in the appropriate position before starting the engine.

Always make sure that all safety equipment installed properly and are in good working order. Do not operate the machine until unsafe conditions have been corrected.

Always operate in a well-ventilated area and make sure that the air filters, air filter covers, and muffler are in good condition.

Always keep the machine clean and free of debris. Operate the machine in a safe and responsible manner. Exercise caution when fueling, working on or near rotating or moving components, hot components, and fuel systems. Be aware of potential fire hazards and prevent sparks, exhaust, etc., from starting fires on the machine and/or work area.

Always comply with all instructions provided on any decals or placards installed on the machine and with any relevant amplifying information provided in this manual or other general operating procedures.

Always disconnect the power source and make sure that all controls are in a safe position and install all appropriate locking and safety devices before doing any of the following:

- Lubricating
- Adjusting
- Installing Tooling
- Making Repairs
- Performing Service

Section 2: Specifications and Installation

Specifications

Width	16 inch / 406 mm
Length	45.5 inch / 1155 mm
Height	35 inch / 889 mm
Weight	95 lbs / 43.1 kg
Hydraulic pressure	max. 2,150 psi / 150 bar
Hydraulic flow	max. 10 gpm / 40 lpm
Idle speed	3,300 U/min / rpm

The machine is designed for outdoors use. It can be used at temperatures between -20 °C to 45 °C (-4° F to 113° F).

The temperature of the hydraulic fluid should be at least 10 °C (50° F).

The statutory minimum distance must be observed around power lines.

Hydraulic fluid

The hydraulic fluid should meet the following requirements.

Viscosity (at 10 °C / 50 °F)	95 cSt
Viscosity (at 38 °C / 100 °F)	27-42 cSt
Viscosity (at 60 °C / 140 °F)	16,5 cSt
Pour point	-10 °C / 14 °F
Viscosity index (ASTM-D2220)	min. 140
Flash point (ASTM-D92)	min. 171 °C / 340 °F
Pump wear test (ASTM-D2882)	max. 60 mg
Demulsibility (ASTM-D1401)	max. 30 minutes

Hydraulic System Specification

The hydraulic unit should ensure a flow rate of at least 10 gpm / 40 lpm and pressure of 2,000 psi / 138 bar.

The pressure must be limited to 2,176 psi / 150 bar.

The measurement must be carried out at the minimum operating temperature of the hydraulic fluid by 10 °C (50 °F). Warm the hydraulic fluid if necessary.

Components



- 1 Handle
- 2 Connection Hydraulic Pump (Supply Flow and Return Flow)
- 3 Frame Rotation Locking Lever
- 4 Lifting Handle
- 5 Spark Guard
- 6 Stone Height Adjustment Hand Wheel
- 7 Hand Wheel Brake Knob
- 8 Guide Wheels
- 9 Roller

Excess weld from the ball of the rail can be removed with the Hydraulic Rail Profile Grinder. Use grinding discs called cup stones with an approximately 6 inch / 15.24 cm diameter and 3 inch / 7.62 cm thickness. The grinding discs must also be suited for use at 3,300 RPM.

The grinding disc is started as soon as the handle is pressed and stopped as soon as the handle is released. There is an additional locking mechanism on the handle to prevent accidental activation of the grinding disc.

Installation

Unpacking Instructions

Upon receiving your Hydraulic Rail Profile Grinder promptly remove it from the shipping container. Always keep the top side of container up. Inspect unit for damage which may have incurred during shipping and report it to carrier for claim.

Tool Preparations

The Hydraulic Rail Profile Grinder requires some assembly before use. If the tool is used in cold weather, preheat the hydraulic fluid by running the power source at low engine speed.

The fluid temperature should be at or above 50° F/10° C before use, when using recommended fluids. Using too thick of fluid may result in tool damage.



WARNING

Never stick foreign objects, fingers, or other extremities into the moving mechanism. Failure to follow these instructions may lead to severe personal injury or tool damage.

Hose Requirements

Check hydraulic hoses for cracks, leakage, and damage. If the hoses or couplers show any of these wear characteristics, replace them before operating the tool. **Never** attempt to locate leaks with your hands, personal injury may occur from pressure system.

It is not often necessary or advisable to use long hoses. All hoses must have an oil resistant inner surface and an abrasion resistant outer surface. Each hose must have male pipe ends for most application.

Longer hoses can be used when necessary but can affect the operation of the tool due to resistance in the hose.

If small diameter or long hoses are used, or if restrictive fittings are connected to the supply and return ports, the pressure required to push the fluid through the system and back to the tank will be higher. This will reduce tool power.

Important: Oil should always flow from the male coupler through the female coupler.

Note: The pressure increases in uncoupled hoses left in the sun. This may make them difficult for them to connect. When possible after use, connect the free ends of the operating hoses together.

The recommended minimum hose diameter for the pressure line hose is 1/2” inside diameter. The pressure line hose must have a minimum working pressure rating of 2500 psi [17.3 MPa].

It is recommended that the hose diameter for the return line hose is 5/8” diameter. If possible, should be greater than the pressure line hose diameter.

These recommendations are intended to keep return line pressure (back pressure) to a minimum acceptable level to ensure maximum tool performance.

All hydraulic hose must meet or exceed specifications set forth by SAE J517.

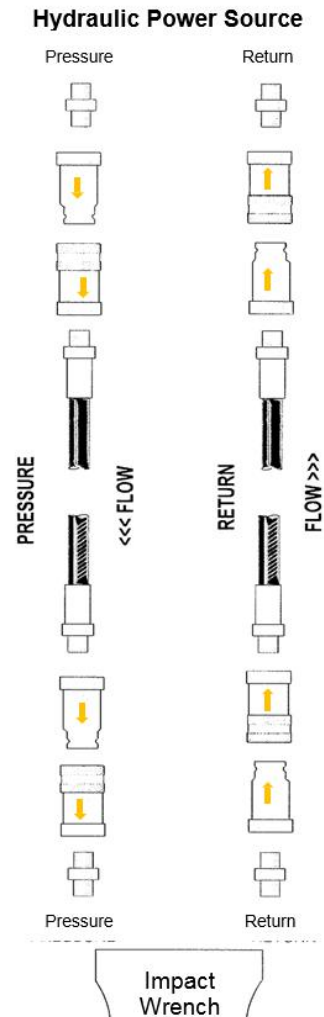

Hose Types

Hydraulic hose types authorized for use with the tool are:

1. **Labeled and certified non-conductive.**

- This is the only hose authorized for use near electrical conductors.
- Constructed of thermoplastic or synthetic rubber inner tube, synthetic fiber braid reinforcement, and weather resistant thermoplastic or synthetic rubber cover.

2. **Wire braided** (conductive)

- This hose is conductive and must **never** be used near electrical conductors.
- Constructed of synthetic rubber inner tube, single or double wire braid reinforcement, and weather resistant synthetic rubber cover

3. **Fiber braided** (not certified or labeled non-conductive)

- This hose is conductive and must **never** be used near electrical conductors.
- Constructed of thermoplastic or synthetic rubber inner tube, synthetic fiber braid reinforcement, and weather resistant thermoplastic or synthetic rubber cover.

The rated working pressure of the hydraulic hose must be at least 175 bar (2500 psi).

Hydraulic Hose Recommendation

Hydraulic Hose Recommendation								
Flow Per Circuit		Length Each Hose		Use	Inside Diameter		SAE Spec Hose (Wire Braid)	SAE Spec Hose (Fiber Braid)
GPM	LPM	Feet	Meter		Inch	MM		
5 to 8	19 to 30	To 50	To 15	Both	1/2	13	SAE 100R1-8	100R7-8
5 to 8	19 to 30	51 to 100	15 to 30	Both	5/8	16	SAE 100R2-10	SAE 100R8-10
5 to 8	19 to 30	100 to 300	30 to 90	Pressure Return	5/8 3/4	16 19	SAE 100R2-10 SAE 100R1-12	SAE 100R8-10 SAE 100R7-12
9 to 12	34 to 45	To 50	To 15	Both	5/8	16	SAE 100R2-10	SAE 100R8-10
9 v 12	34 to 45	51 to 100	15 to 30	Pressure Return	5/8 3/4	16 19	SAE 100R2-10 SAE 100R3-12	SAE 100R8-10 SAE 100R7-12
9 to 12	24 to 45	100 to 200	30 to 60	Pressure Return	3/4 1	19 25.4	SAE 100R2-12 SAE 100R1-16	SAE 100R8-12 SAE100R7-16

The rated working pressure of the hydraulic hose must be at least 2500 psi / 173 bar.

The temperature of the hydraulic fluid must be limited to 60° C (140° F).

Hydraulic Fluid Recommendation

Inspect hoses for cuts, crushing, leaks, or abrasion, which may be a safety hazard or reduce fluid flows.

The following fluids work well over a wide temperature range at startup, allow moisture to settle out, and resist biological growth likely in cool operating hydraulic circuits.

Others that meet or exceeds the specifications of these fluids may also be used.

Type	Hydraulic fluid
Amsoil	AWH ISO 32
Chevron	Rando HD Premium Oil MV ISO VG 32 Rando HDZ ISO 32
Gulf	Harmony AW ISO Multi-Grade 32
Mobil	DTE Oil Excel 32
Schaeffer	Dilex Supreme Hydraulic Fluid w/ Dynavis ISO 46.
Shell	Shell Tellus S2 VX 32
Sunoco	Sunvis 1032 HVI Hydraulic Oil

Tool Connecting Procedures

1. Stop the engine before connecting the tool and or hoses to the power unit, and when switching hoses or tools.
2. Turn the hydraulic on/off valve to the off position before starting the engine.

Make sure all hoses are connected for correct flow direction to and from the tool being used.

When routing hose in the work area, position them where personnel will not be at risk of tripping over them where vehicles can run over the hoses. Do not lay hose over sharp objects.

**WARNING**

Pressurized fluid escaping from a damaged hose can penetrate the skin and be injected in the body causing injury or death.

Do not pull on hoses to drag the power unit or tool.

Connecting Hoses

1. Wipe quick couplers with a clean lint free cloth before connecting them.
2. Depressurize the system.
3. Allow system and hydraulic fluid to cool if too hot to handle.
4. Securely connect the return (tank “R”) hose from the power source to the tool.
5. Securely connect the supply (pressure “P”) hose from the power source to the tool.

It is recommended that you connect the return hoses first and disconnect last to minimize or avoid trapping pressure within the tool.

When connecting the quick couplers, the flow should run from male coupler to the female coupler. The female coupler on the tool is the inlet. Quick couplers are marked with a flow direction arrow.

**WARNING**

Pressurized fluid escaping from a damaged hose can penetrate the skin and be injected in the body causing injury or death.

Do not pull on hoses to drag the power unit or tool.

Note: When possible, connect the free ends of uncoupled hoses to prevent build up in the hoses. The sun can also increase pressure in the hoses and make connecting them difficult.

Disconnecting Hoses

1. Stop the hydraulic power source.
2. Depressurize the system.
3. Allow system and hydraulic fluid to cool.
4. Disconnect the supply (pressure) hose from the power source (pressure port) from the tool (IN port).
5. Disconnect the return (tank) hose to the hydraulic power source (return port) from the tool (OUT port).
6. To prevent contamination, always install dust caps over the hydraulic ports of the tool when disconnected.

Section 3: Tool Operation

Personal Protective Equipment



Before operating this machine, make sure that all general safety precautions are observed, and that proper personal protective clothing is worn as described below.

At a minimum, operators should wear the following Personal Protective Equipment:

1. Safety Glasses
2. Hearing Protection
3. Hard Hat
4. High Visibility Safety Vest
5. Leather Work Gloves
6. Steel Toed Safety Shoes

Grindstone Installation

Grindstone with a diameter of 17.24 cm (6 inches) and a thickness of 7.62 cm (3 inch) must be used with the Hydraulic Rail Profile Grinder. The grindstones must be suited for use at 3,300 RPM. Check the grinding discs for damage before using. Damaged grinding discs may not be mounted.

1. Align the hole in the frame with the hole in the motor spacer.

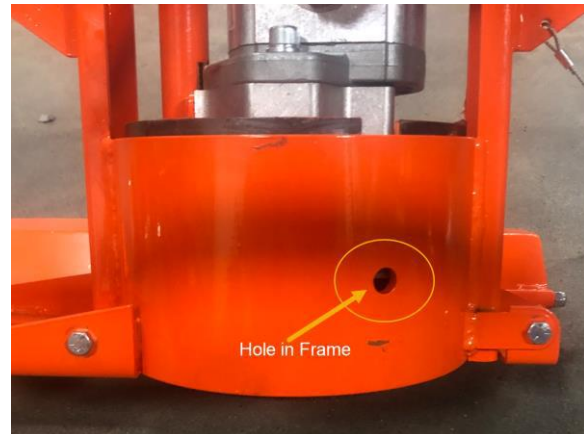

2. Insert the stone locking pin through the holes in the motor spacer. If the pin doesn't slide through the holes easily, adjust the stone housing until it does.
3. Hold the stone locking pin in and turn the stone by hand counter-clockwise (left) until the pin locks the shaft.
4. Place the stone removal tool (option) around the stone and loosen the stone.

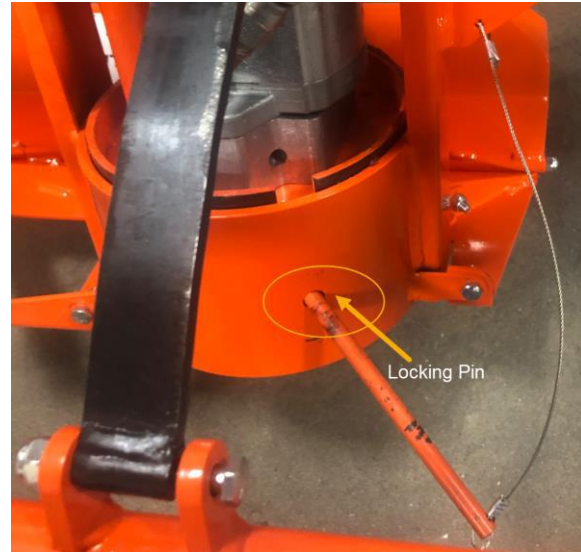

5. Once the stone has been loosened, it can be turned by hand and removed.
6. Check that the blotter came off with the stone and didn't stick to the inner surface of the backup flange.
7. Check that the backup flange is pressed all the way on the spindle shaft. The square on the spindle should slide into the square in the back of the backup.

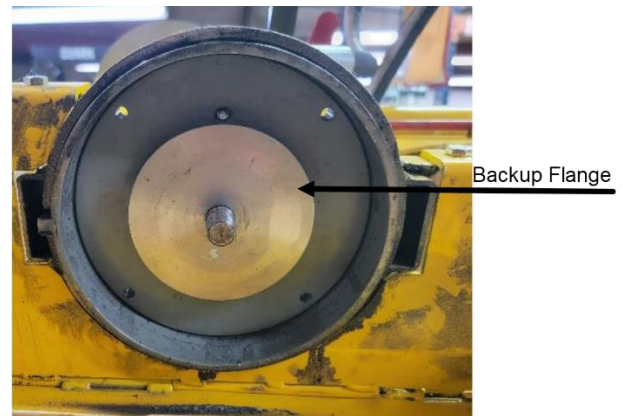
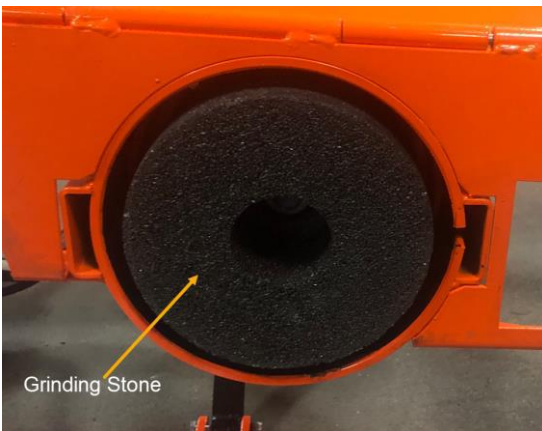

8. Use new blotters between the stone and backup flange.

The blotters should be supplied with stones. They are made of highly compressible material and should not be more than 0.025" thick.

9. Turn the spindle end until the backup flange contacts the stone.
10. After the new stone has been installed, return the stone locking pin to its storage location.
11. After mounting the new grinding disc let the mounting disc run at full speed for a minute before beginning grinding.

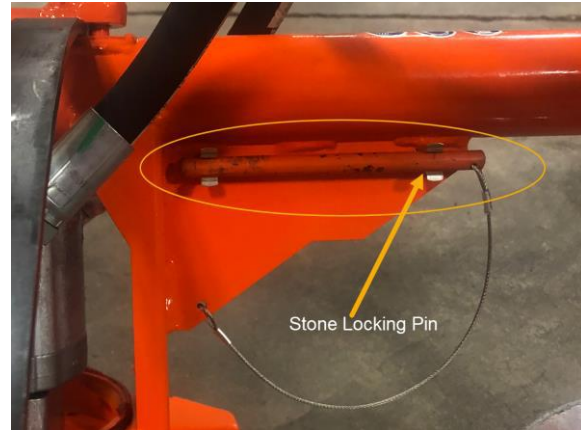

Grinder Functional Test

1. Make sure that the operating lever can be easily moved.
 - If the operating lever is difficult to move, check for damage. If the Hydraulic Rail Profile Grinder is damaged, stop the test and have the Hydraulic Rail Profile Grinder repaired.
2. Make sure that the grinding disc is securely mounted and that all safety devices are tightly fastened.
3. Connect the Hydraulic Rail Profile Grinder to the hydraulic unit.
4. Switch the hydraulic unit on.
5. Hold the Hydraulic Rail Profile Grinder tight with both hands.
6. Release the locking mechanism while pulling the operating lever.
7. The grinding disc must turn.
8. Let go of the operating lever.
 - The grinding disc must stop.
 - If the grinding disc does not turn or does not stop, stop the test and have the Hydraulic Rail Profile Grinder repaired.

Stone Height Adjustment

The stone can be adjusted to a desired height by turning the large hand wheel at the center of the Hydraulic Rail Profile Grinder. The smaller knob located under the hand wheel is used as a brake to increase or decrease drag on the hand wheel.

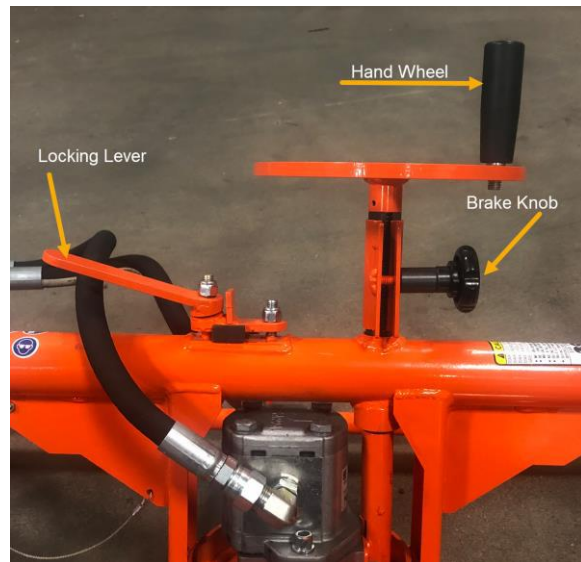

Operation

A visual inspection is to be carried out before beginning work. In the event of damage, no work may be carried out. Install hydraulic hoses away from walking and transport routes. Make sure that hydraulic hoses are not installed over sharp edges. Make sure that the environment is well lit; set up additional work lights if necessary.

1. Remove the dust covers from the quick couplings.
2. Clean the quick couplings.
3. Connect the Hydraulic Rail Profile Grinder with the return flow of the hydraulic unit.
4. Connect the Hydraulic Rail Profile Grinder with the supply flow of the hydraulic unit.

Ensure that the flow and return flow of the hydraulic unit are connected to the correct quick coupling.

When connecting the quick couplings, the flow should run from male coupler to the female coupler. The female coupler on the tool is the inlet. Quick couplers are marked with a flow direction arrow.

The hydraulic unit must be switched off and without pressure for connection.

5. Start the hydraulic unit.
 6. Adjust the stone to the required height for grinding the weld.
 7. Hold the Hydraulic Rail Profile Grinder tight.
 8. Turn the control valve to the “ON” position.
 9. With the grinder at full speed, move it from right to left into the weld.
 10. Adjust the stone height and rotate the frame as required for optimum results.
 11. To stop the grinding disc, let go of the operating lever and allow stone to stop before removing from the rail.
-
12. Switch the hydraulic unit off after grinding.
 13. Depressurize the system.
 14. Allow the hydraulic fluid to cool.
 15. Disconnect the supply flow from the Hydraulic Rail Profile Grinder.
 16. Disconnect the return flow from the Hydraulic Rail Profile Grinder.
 17. Protect the quick couplings with dust caps.

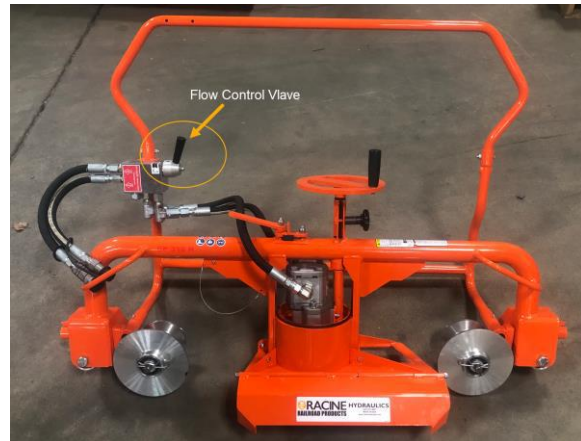

Frame Rotation

The Hydraulic Rail Profile Grinder’s frame can be set at any position within a 90° arc by loosening the locking lever and pulling the frame toward the handle. Always turn the locking lever into a locked position before grinding.

Positioning on the Rail

Place the Hydraulic Rail Profile Grinder on the rail with the two large diameter guide wheels on one side of the rail and the other two smaller diameter wheels on the opposite side. The grinder should set on the rail at each roller and roll back and forth freely.

When grinding with the Hydraulic Rail Profile Grinder, position the weld between the left set of wheels and the stone housing (left and right are determined from the operator’s position at the handle).

Adjust the stone to the required height for grinding the weld.

Section 4: Maintenance

It is highly recommended to practice regular check-ups and maintenance in accordance with the usage frequency to keep your tool in better condition and reduces total running costs.



WARNING

Do not perform maintenance on the machine while the hydraulic power source motor is running or when hoses are connected.

All maintenance must be done with the tool disconnected from the power source.

Cleaning and Maintenance Recommendations

- Wipe all external surfaces after each use with a clean, lint free cloth to remove surface contaminants from the tool.
- Store all tools in an enclosed area to prevent the weather from contaminating their systems.

Safety Devices

When maintenance is complete, make sure the following:

- The hydraulic control valves are operable.
- The hydraulic quick couplers and hoses are safe to use.

Storage Preparation

- Cover male and female hose whips.
- Store in the upright position. Secure tool to prevent it from being knocked over.
- Store the Web Grinder on a smooth level surface.
- The tool should be stored in a cool, dry environment which is not subjected to rapid temperature changes.

Daily



WARNING

Do not attempt to locate hydraulic leaks by feeling around hoses and fitting with hand. Pin-Hole leaks can penetrate the skin.

- Wipe all tool surfaces, fittings, and couplings free of grease, dirt, and foreign materials.
- Inspect the tool, hydraulic system, hoses, and fittings for signs of leaks, cracks, wear, and/or damage. Replace if necessary.
- To prevent contamination, always install dust caps over the hydraulic ports when disconnected.
- Inspect machine for damage and wear, replace as required.

Monthly

- Perform a detailed inspection of the systems hoses and fittings according to the hydraulic hose operator's manual and as stated in SAE standard j1273, May 1989 or latest revision.

Replace the hoses and/or fittings if necessary.

Troubleshooting

Use the following chart as a guide to correct any problem you may experience with the too.

To determine the problem in operation of the grinder always check that the hydraulic power source is supplying the correct hydraulic flow and pressure to the tool as listed in the table.

Be sure you are using an accurate flowmeter. Check the flow with the hydraulic fluid temperature at least 50° F / 10° C.

Maintenance Schedule

Components, for which wear and tear or even malfunction is determined during inspection, must be repaired, or replaced as soon as possible.

Components	Inspection	Intervals
Entire device	Cleaning	The entire device must be cleaned with a lint-free cloth at the end of the shift.
	Visual inspection	The entire device must be checked for damage daily. Damaged parts must be replaced.
Hydraulic system	Visual Inspection	The hydraulic system must be checked for leaks, cracks, wear and/or damage daily. Damaged components must be replaced.
	Inspection	Check hoses and fittings for leaks monthly.
Hydraulic fittings	Visual inspection	To prevent contamination, always install dust caps over the hydraulic fittings when disconnected.
Grinding stone	Visual inspection	Check the grinding stone for damage or wear before and after each use. Damaged grinding discs may not be used.
Grinding stone guard and fasteners	Inspection	Check the grinding stone fasteners and guard. Keep fasteners tight and guard in good condition.

Troubleshooting

Problem	Cause	Remedy
Tool will not run.	Power source.	Check power source flows and pressure (8-10 gpm / 30-38 lpm at 1500-2000 psi / 100-140 bar).
	Coupler or hoses.	Check for/remove obstruction.
	Mechanical failure.	Disassemble tool and check for damage.
Tool runs backwards.	Pressure and return reversed.	Correct hose connection or flow direction. Motor shaft rotates clockwise as viewed from the end of the shaft.
Hydraulic fluid leaks from spindle.	Damaged motor seal.	Disassemble tool and replace seal.
Grinder grinds too slow.	Insufficient fluid flow or low relief valve setting.	Adjust flow for proper gpm. For best performance to 2100-2250 psi / 145-155 bar.
Trigger (ON/OFF) hard to press.	Back pressure too high.	Should not exceed 250 psi / 17 bar at 10 gpm / 38 lpm.
	Pressure and return reversed.	Correct for proper flow direction
	ON/OFF mechanism blocked.	Check on/off mechanism. Remove obstruction if present.

Section 5: Parts and Service Support

Technical Support & Service

Telephone and web-based technical support is available for current production models through our Customer Service Department. Service Manuals and limited technical support may be available for models that are no longer in production.

Telephone and E-mail Technical Support

Telephone and e-mail technical support is available on normal U.S. business days from 8:00 AM to 5:00 PM U.S. Central Time Zone (GMT +6 (+5 Daylight Savings Time)).



1955 Norwood Court

Mount Pleasant, WI 53403

Phone: (262) 637-9681

Email: custserv@racinerailroad.com
racinerailroad.com



Unit 3 Hartington Industrial Estate

Chesterfield • Derbyshire, S43 3YF

Phone: 0330 164 1375

Email: info@racinerailroad.co.uk
racinerailroad.co.uk

Non-Warranty Technical Support

Depending upon the circumstances and availability of technical service personnel, we may provide technical assistance and/or field service support, *at the customer's expense*, to assist in the correction of non-warranty related problems. Contact our Customer Service Department to coordinate Non-Warranty Technical or Field Service Support.

Warranty Support Technical Support

Depending upon the circumstances and availability of technical service personnel, we may provide technical assistance and/or field service support, *at no charge to the customer*, to assist in the correction of warranty related problems. Contact our Customer Service Department to coordinate Warranty Technical or Field Service Support.

Warranty Parts Claims

Material claimed to be defective must be returned to our factory for evaluation. Defective materials will be replaced, or your account will be credited if replacement materials have already been purchased. Please contact our Customer Service Department at the address provided below if you have any questions or problems.

Warranty Service Support

Depending upon the circumstances and availability of technical service personnel, we may provide technical assistance and/or field service support, at no charge to the customer, to assist in the correction of warranty related problems. Contact our Customer Service Department at the address provided above to coordinate Warranty Service Support.

On-Off Rotary Valve Exploded View & Parts List

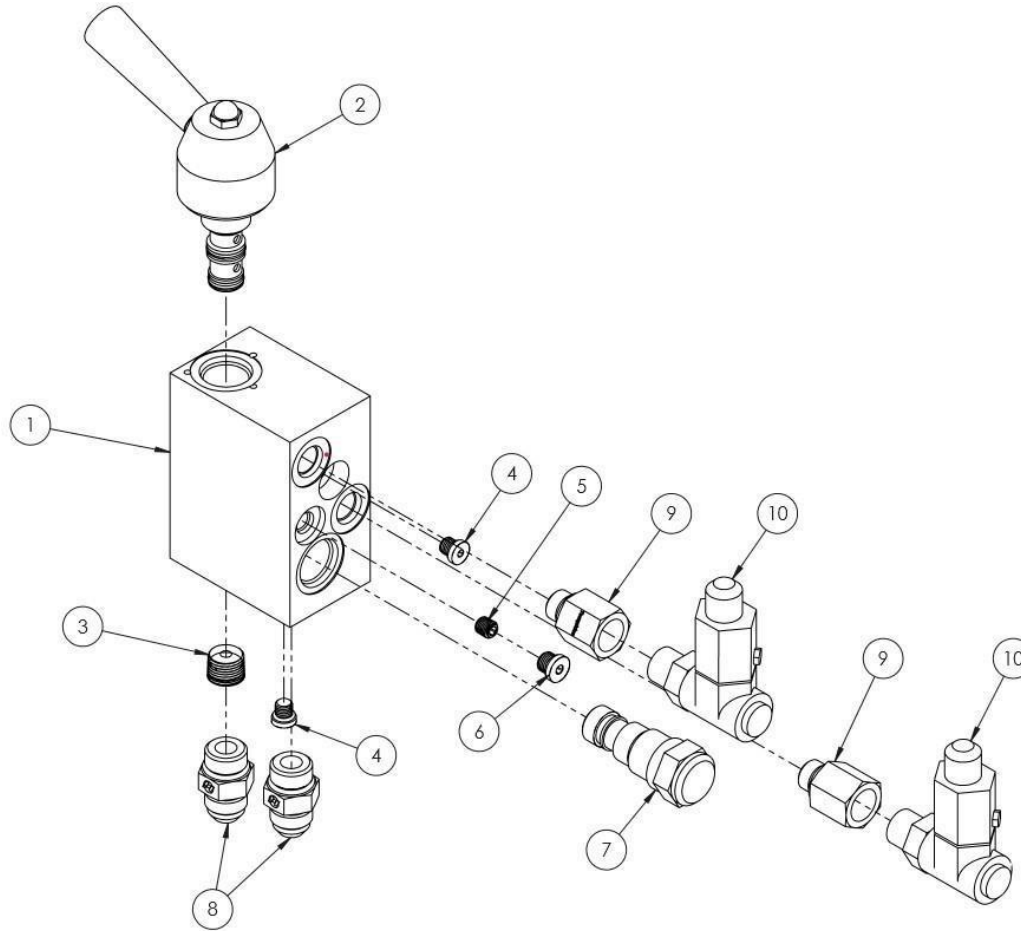

Part No	Description	Qty.	RRP Part Number
1	MANIFOLD, ROTARY ON/OFF VALVE	1	
2	VALVE, ON/OFF ROTARY	1	
3	ORFICE, .203	1	471452
4	PLUG, 5/16-24 O-RING HHP	2	
5	ORIFICE, .024	1	
6	PLUG, 3/8-24 O-RING HHP	1	
7	VALVE, #DPS2-10-P-F-O-80	1	
8	ADAPTER, -8MJIC X -8MORB	2	
9	ADAPTER, -6MORING X -6FMNPT	2	
10	ADAPTER, -8MJIC X -6MNPT 90SWIVEL	2	1000348

Motor Exploded View

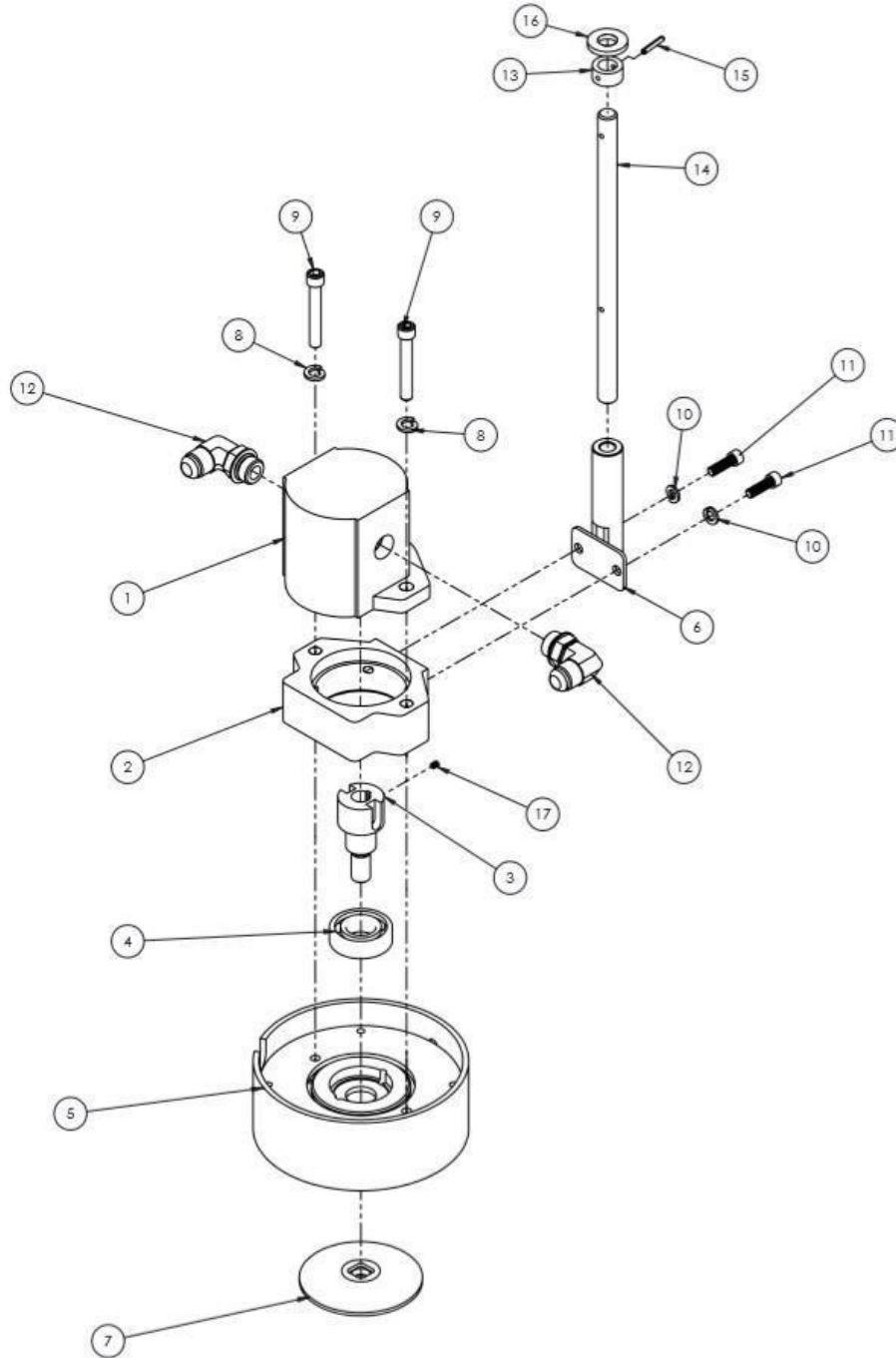

Motor Exploded View Parts List

Part No	Description	Qty.	RRP Part Number
1	MOTOR, PLM201125031S1LOC/OCNHEL	1	10000363
2	SPACER, MOTOR	1	
3	SPINDLE	1	10000326
4	BEARING, BALL	1	
5	HOUSING, STONE	1	471732
6	ADJUSTER, HEIGHT	1	
7	PLATE, BACKUP STONE	1	
8	LOCK WASHER, 3/8 SPLIT	2	
9	BOLT, 3/8-16 X 2-1/2 SKTHD ZP	2	
10	LOCK WASHER, SPLIT	2	
11	BOLT, 5/16-18 X 1" SHCS SS	2	
12	ADAPTER, -10MORB X -10MJIC 90	2	
13	COLLAR, STOP	1	
14	ROD, THREADED	1	
15	PIN 5/32 X 1 ROLL	1	
16	WASHER, 5/8 SPECIAL FLAT	1	471671
17	SCREW, #10-32 X 1/4 SOC SET	1	471055

Handle Exploded View & Parts List

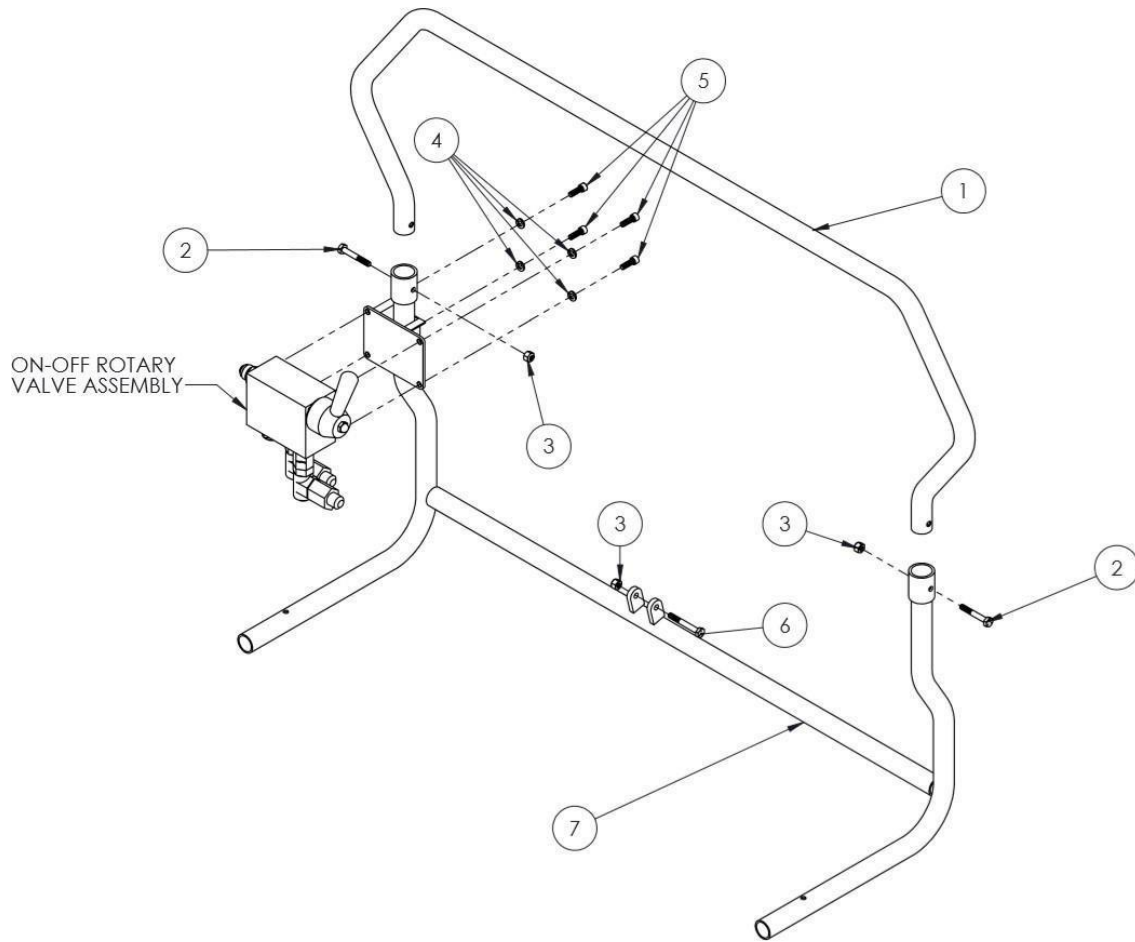

Part No	Description	Qty.
1	TUBE, MAIN HANDLE	1
2	GRADE 5 BOLT, 1/4-20 1-3/4	2
3	GRADE 5 NUT, 1/4-20	3
4	LOCK WASHER, SPLIT	4
5	BOLT, 1/4-20 X 3/4 SHCS	4
6	BOLT, 1/4-20 X 2 HH ZP GR5	1
7	FRAME, PROFILE GRINDER HANDLE	1
8	EXPLODED VIEW	1

Frame Exploded View & Parts List

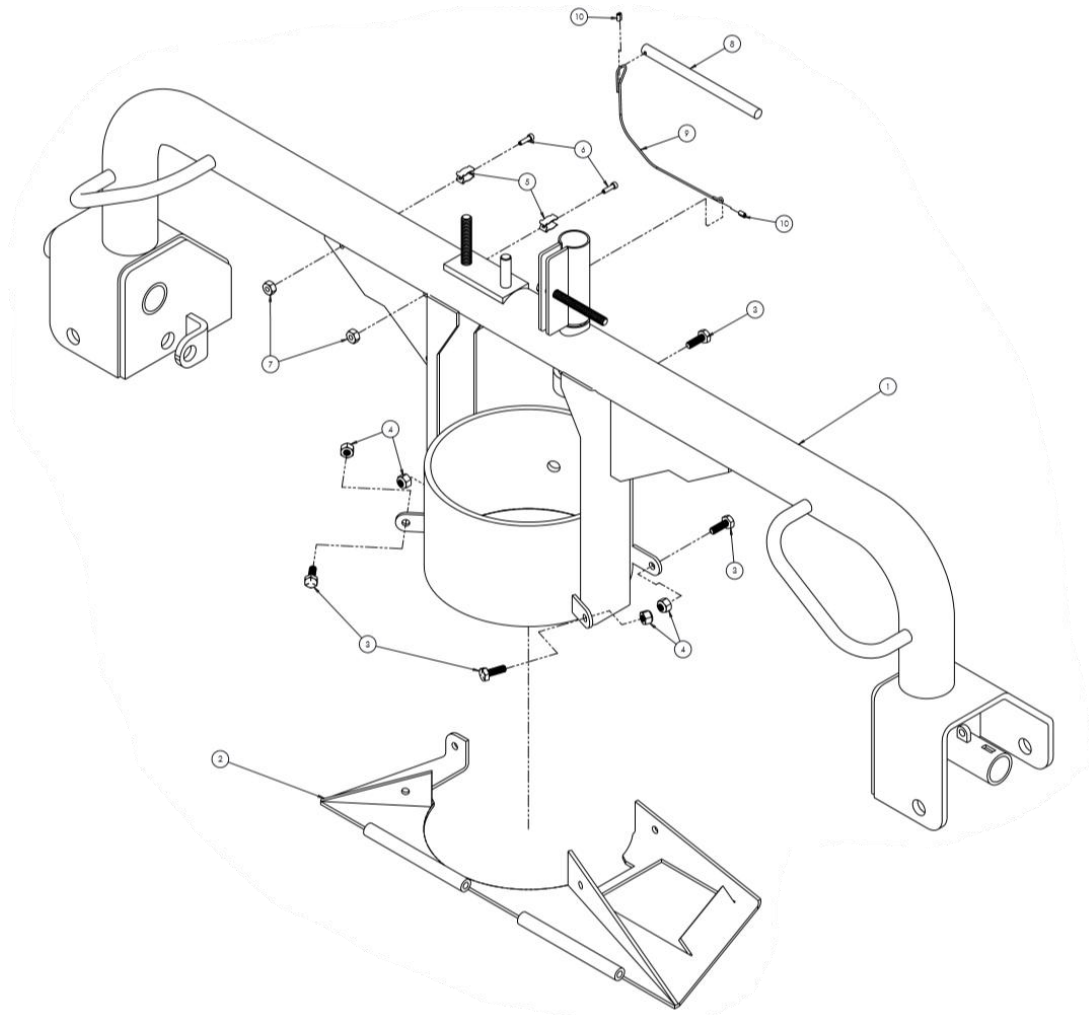

Part No	Description	Qty.
1	FRAME, PROFILE GRINDER MAIN	1
2	GUARD, MAIN SPARK	1
3	GRADE 5 BOLT, 1/4-20 X 3/4	4
4	GRADE 5 NUT, 1/4-20	4
5	CLIP, PIN HOLDER	2
6	BOLT, 6-32 X 1/2 SHCS SS	2
7	NUT, 6-32 HEX SS	2
8	PIN, STONE LOCKING	1
9	CABLE, PIN RETAINING 1/16 X 8.00	1
10	CLAMP, CABLE	2

Profile Grinder Exploded View

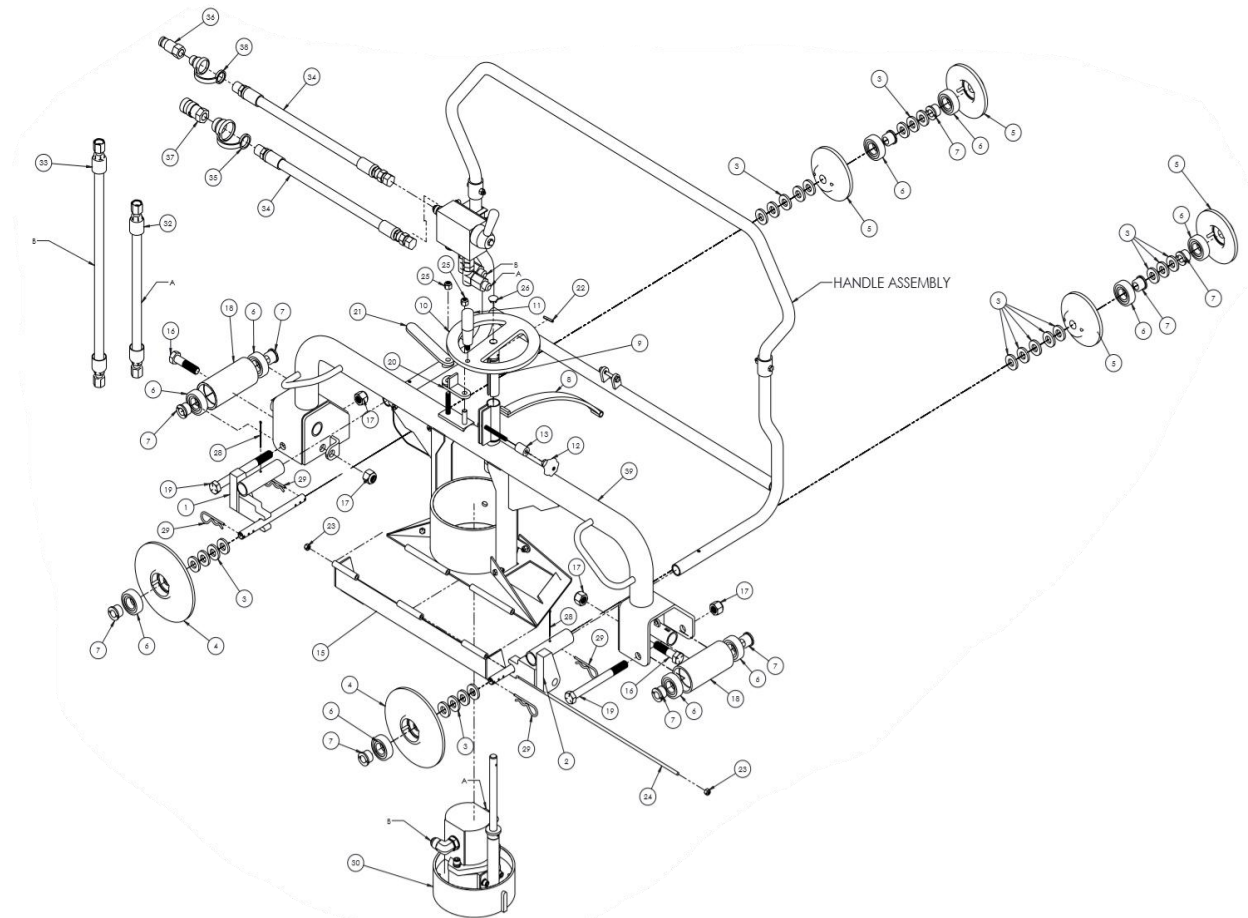

Profile Grinder Exploded View Parts List

Part No	Description	Qty.	RRP Part Number
1	PIVOT, RIGHT WHEEL	1	
2	PIVOT, LEFT WHEEL	1	
3	WASHER, 5/8 SPECIAL FLAT	24	
4	WHEEL, OUT	2	
5	WHEEL, INNER	4	
6	BEARING	10	
7	BUSHING, ROLLER	10	
8	BAR, ANGLE	1	
9	BUSHING, NYLON	1	
10	WHEEL, HAND	1	
11	HANDLE, REVOLVING	1	
12	KNOB LOCKING #5TBA1	1	475063
13	SPACER, PLASTIC	1	475059
14	NUT, 5/16-18 NYLOCK	1	

15	GUARD, PROFILE GRINDER SPARK	1	
16	BOLT, 5/8-11 X 2-½ HH ZP GR5	2	
17	NUT, 5/8-11 ZP NYLOC	3	
18	ROLLER	2	
19	BOLTM 5/8-11 X 6-½ HH ZP GR5	2	475645
20	LINK, LOCKING	1	
21	LEVER, LINKING	1	
22	PIN, 5/32 X 1 ROLL	1	
23	GRADE 5 NUT, ¼-20	2	
24	ROD, THREADED HINGE	1	
25	NUT, 3/8-16 HH NE NYLOK	2	
26	CAP, PLUG #9563K44 5/8	1	10000405
27	BLOCK, LEFT AXLE	1	
28	KEY, 5/32 X 2 COTTER	2	
29	PIN, HAIR #10	4	472154
30	EXPLODED VIEW	1	
31	EXPLODED VIEW	1	
32	HOSE, ½ X 17" -8-10FMJIC/-8-8FMJIC	1	
33	HOSE, ½ X 24" -8-10FMJIC/-8-8FMJIC	1	
34	HOSE, ½ X 18" -8MNPT/-8FMJIC	2	
35	COVER, COUPLER FM	1	
36	NIPPLE HYD, 6FP M	1	
37	COUPLER HYD, 6FP F	1	
38	COVER, COUPLER M	1	
39	EXPLODED VIEW	1	

Section 6: Warranty Terms and Conditions

Warranty Period

Each new machine and new parts of our manufacture are warranted against defects in material and workmanship for one year from the date of shipment from our factory.

When contacting customer service for factory parts, service or warranty support please provide the:

- Racine Railroad Products Model
- Serial Number
- Any locally assigned identification

Vendor Parts Warranty Period

Other equipment and parts used, but not manufactured by Racine Railroad Products, Inc., are covered directly by the manufacturer's warranty for their products.

Warranty Parts and Service

We will repair or replace, without charge, F.O.B. factory, Racine, Wisconsin, USA, any part Racine Railroad Products manufactures which is proven to be defective during the warranty period.

Material claimed defective must be returned, if requested, to the factory within 30 days from the date of the claim for replacement. Ordinary wear and tear, abuse, misuse, and neglect are not covered by this warranty. Depending upon the circumstances, we may provide technical assistance and/or technical service support, without charge, to assist in the correction of warranty related problems.

Non-Warranty Parts and Service

Material damaged through normal wear and tear, abuse, misuse and/or neglect are not covered by our warranty and should be ordered directly from Customer Service.

Note: Parts for models that are no longer in production may not be available.

Non-Warranty Parts Orders

When placing a parts order please provide the following information:

- Company Name and Billing Address
- Purchase Order Number and Issuing Authority
- Shipping Address
- Special Handling Instructions
- Contact Phone Number
- Machine Model and Serial Number
- Part Numbers and Quantities Being Ordered

Note: Please use Racine Railroad Products part numbers when ordering parts. Racine Railroad Products part numbers are shown in the parts lists and drawings of this manual and have only six (6) numbers.

Any part number with other than six numbers (e.g., contains alpha-numeric characters) is a Vendor Part Number and **not** a Racine Railroad Products part number